

Steel CONnections

Design and optimization of connections has never been that easy

1 DEFINE THE NODES IN THE STRUCTURAL MODEL

From the structural model of SOFiSTiK analysis you can select all the nodes according to the connection between the steel members. STEelCON will automatically identify the correct position for each member in the connection for you.

All the data can be selected using graphical interface such as SOFiSTiK animator or D.A.I.S.Y. and are later presented as a detailed image, or as text in grids, fully editable by the user.

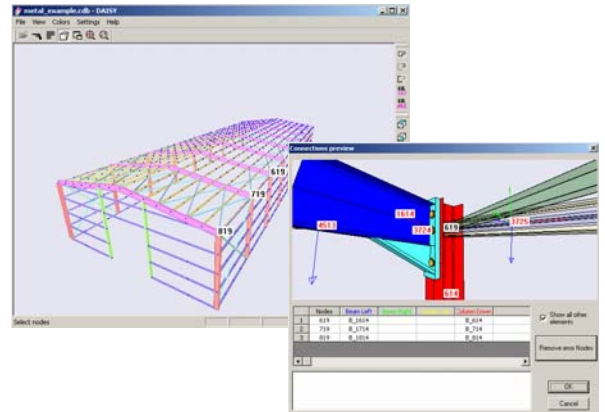

2 DESIGN AND OPTIMIZE THE CONNECTIONS

The user becomes familiar with the interface of the program from the very first use by using tools such as auto-refreshing connection drawings and distances check after every modification.

The engineer gets informed about the exploitation of all the components of the connection and has full control in decreasing or increasing their capacities. The same connection can be designed for more than one node of the structural model and for all the loadcases, presenting all results on screen in every detail

3 PRINT THE REPORTS AND DETAIL DRAWINGS

All the results can be exported in RTF files and edited by any word processor, as the embedded in STEelCON STCONView, Microsoft Word etc. Also the user can select to export the results in .plb format for the SOFiSTiK Ursula document manager. A basic theory chapter is added to the report for every connection together with the results and connection and loadcase drawings. The user can define the depth of detail that will be presented in the printouts.

The detail drawings of all the connection types can be exported to any CAD system by using the DXF protocol. For each connection STEelCON generates all the necessary views and shop drawings for all the members and plates that are participating. All the necessary layers and linetypes are automatically generated, and the user can select between standard or custom scales.

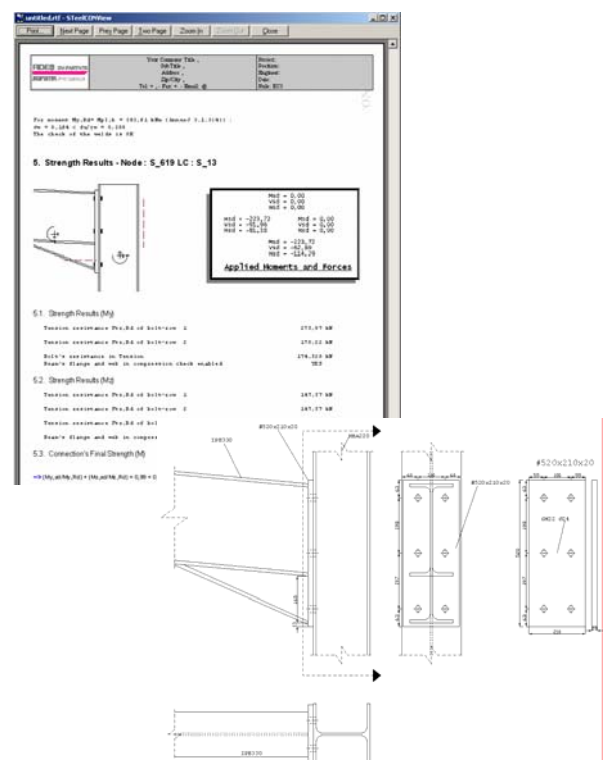

STeel CONnections

Connection Types

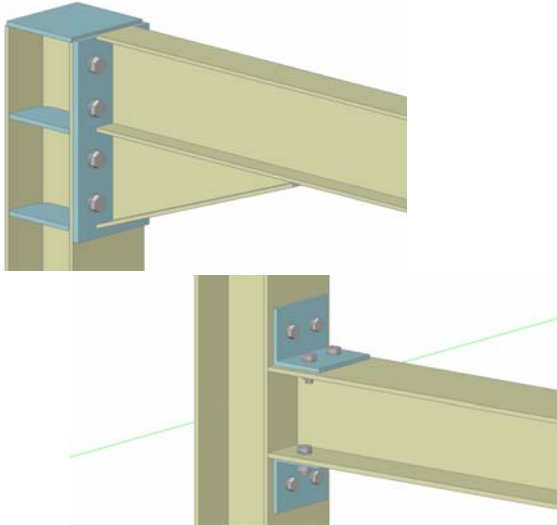

- Moment frame connections. Connections of this type may be welded or bolted using end plate (extended or flush) or using angle cleats. The solution and dimensioning procedure is based on Annex J of EC3 and on DIN18800 according to users' preferences.
- Many types of stiffener plates can be used such as Column Web Stiffeners, Column Flange Stiffeners, Horizontal or Diagonal Stiffeners.
- Rotational and strength Stiffness are being calculated.
- Unlimited configuration variations may be produced.

- Shear connections using angle cleats. The calculation and dimensioning are based on either EC3 or DIN18800 according to users' preferences.

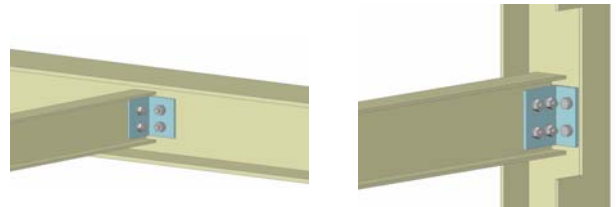

- I-Type beam splice connection. This connection may be bolted, welded or mixed (bolted at one side and welded at the other). The calculation and dimensioning are based on either EC3 or DIN18800 according to users' preferences.

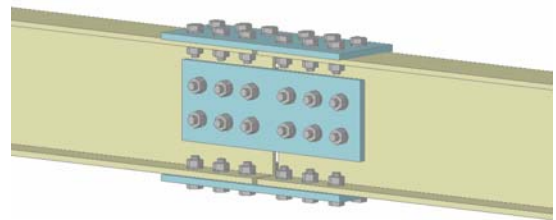

- Hollow section lattice girder connections of type K and N. The chord of the connection may be I, H, UPN, or Hollow Section circular or rectangular. The braces may be hollow Section circular or rectangular. In addition there is the ability to select between overlapped or gapped braces. The calculation is based on Annex K of EC3.

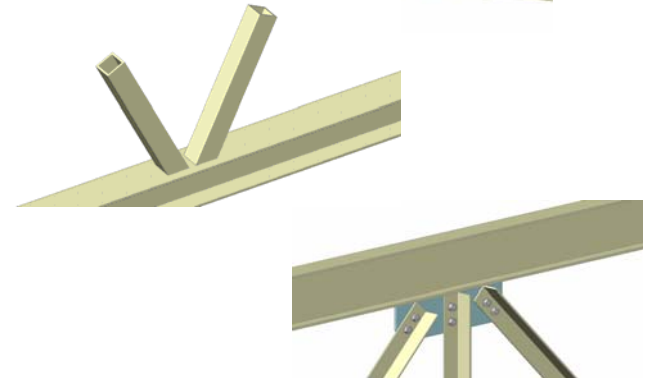

- Gusset plate connections. The members can be connected in both sides of the gusset plate and may have eccentricity. The program calculates moment, shear and axial forces due to eccentricity of the connected members. The calculation and dimensioning are based on EC3.

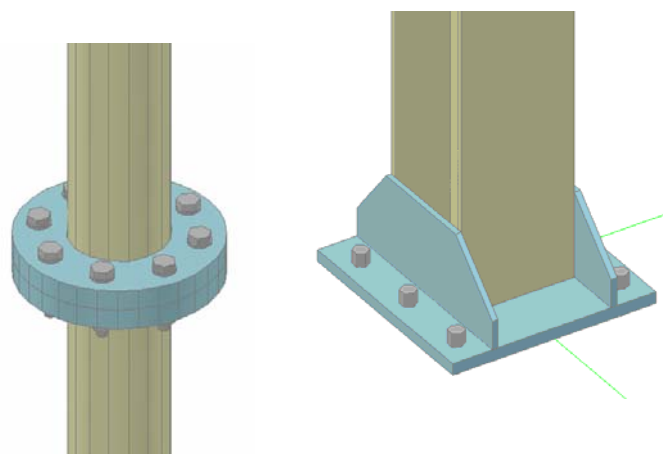

- Column base connections. The program covers both moment and shear connections and the calculation are based on Annex L of EC3. The user may select from 2 (pinned connection) to 8 anchors of three different types or user defined ones. He also may select to use stiffener plates and a shear element below the base plate. The calculation and dimensioning are based on EC3.

- Tubes splice connections. The program calculates the interaction of all internal forces including torsional moment. The results of the equilibrium and welds stresses are graphically presented. The calculation and dimensioning are based on EC3.

New Features in SteelCON Version 2007.108

New Connection type : End Plate Splice Connection

The End Plate Splice Connection includes all the possible features that are also available to the Beam to Column Connection

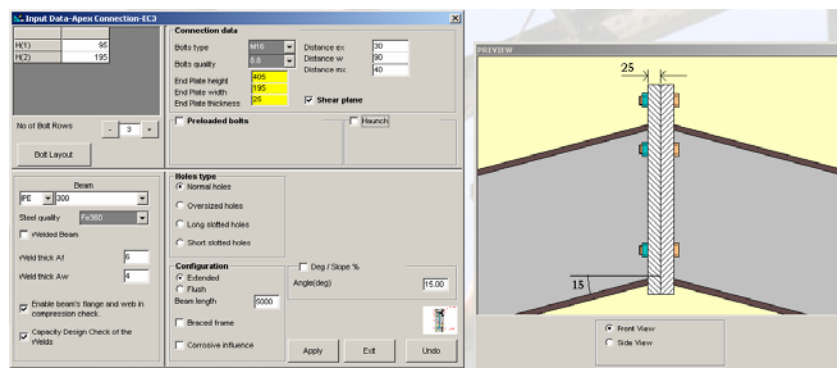
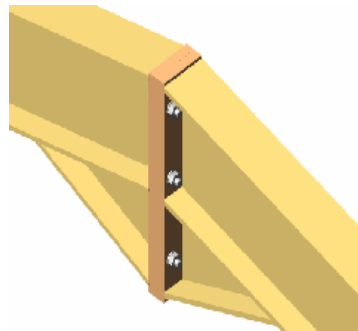

Automatic Bolt Layout

All the parameters for automatic bolt layout are now freely open to the user, and are set in relation to the hole diameter.

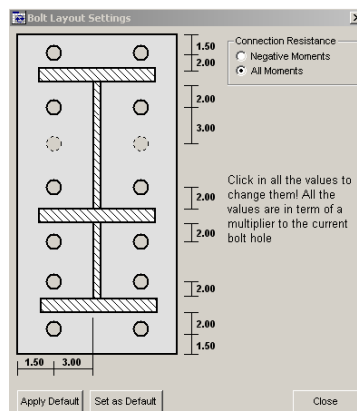

Optimization for Beam to column Connections

Beam to Column Connections can be optimally configured according to specific design criteria and restrictions :

- Optional or Maximum design type
- Select which types of reinforcements are allowed
- Select between any bolt type and any bolt quality
- Select the range of bolt rows number desired. The program will automatically reject the connections with bolt distance errors.

All possible configurations of the Beam to Column Connection are available for the optimization

